



READ THIS !

The following sheets contain way more detail and info than most venues need.

Ultimately, all Mark needs to perform is a room with a 2 channel sound system and some basic lights.

*For gigs within an 8 hour drive of Charlottesville, Virginia Mark only needs a place to perform and can bring and run **EVERYTHING ELSE.***

DON'T PANIC

These pages are designed as a guide to help reduce tech time and make the process easy for all parties. This particular set of pages are for Performing Arts Centers, Theaters and Cruise Ships. Please see the appropriate tech sheets for corporate and other events on Mark's web site.

Most pages here are for setup and backup **ONLY**.
Mark typically **RUNS EVERYTHING HIMSELF.**

Remember Mark is **VERY FLEXIBLE** and can adjust to **ANY SITUATION** and equipment available.

Look forward to working with you.

Mark Nizer

For more info visit **Nizer.com**

A downloadable version of this can be found at: <http://www.nizer.com/pages/resources.html>

Mark Nizer • 434 974 9699 • mark@nizer.com



TECH GUIDE

Stage Plot



Needed on stage:

- 4 XLR Mic cables
- 2 Direct Boxes (Optional) (See **Sound** page for setup options.)
- 2 Grounded Power Cords
- 2 Grounded Power Strips or Quad Boxes
- 1 Sound Monitor (optional)
- 1 Movie Screen, White Cyc or Light Colored Wall (as far down
- 1 Projector with VGA, DVI or HDMI Projector input (NOTE: Put the video input cable where the other audio cables are. The preferred location is stage right).

READ THIS: If Mark is driving to your event he will bring the power & XLR cables with him. He may even bring the sound system, projector & lights depending on the venue & your situation.

Supplied By Artist:

- A small paper box may be attached to a fly pipe, light bar or border.
- A ball drop may be attached to a fly pipe, light bar, ceiling or acro wire.

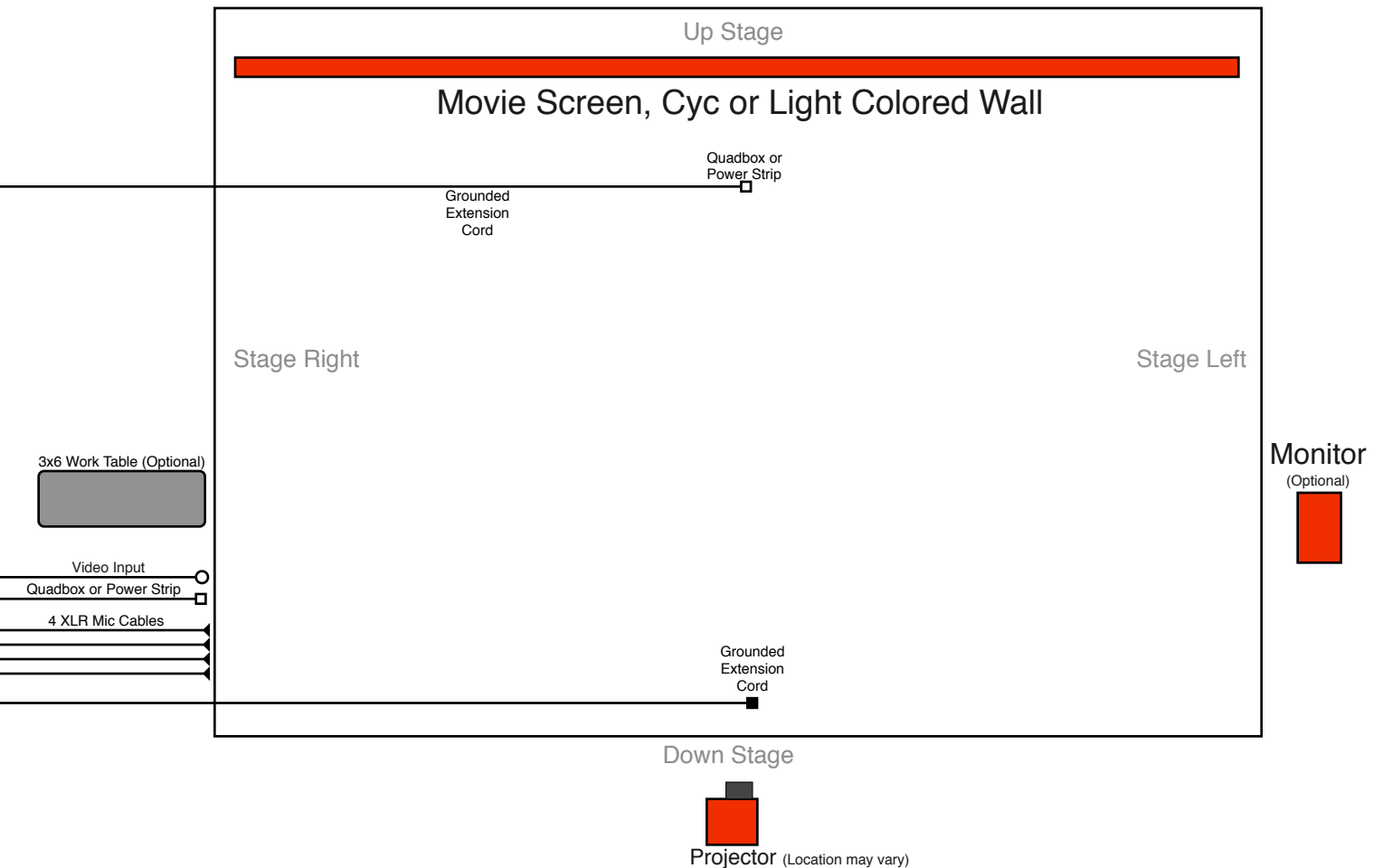



For more info visit [Nizer.com](http://www.nizer.com)

A downloadable version of this can be found at: <http://www.nizer.com/pages/resources.html>

Mark Nizer • 434 974 9699 • mark@nizer.com



Items Needed on Stage:	Items Needed in Dressing Room:
<p>1 VERY LARGE Apple - any variety (per show).</p>	<p>1 Rip Banana (per show)</p>
<p>2 - 1 qt bottles of water (per show).</p>	<p>2 bottles of room temperature water (per show)</p>
<p>2 Rolls of Scott™ Toilet Tissue (per show).</p>  <p>(bought in a four pack)</p>	<p>HOSPITALITY:</p> <hr/> <p>Food:</p> <p>Spicy Thai (Thai Hot Red Chicken Curry & Chicken Pad Thai)</p> <p>Indian (Spicy Chicken Tikki Masala & Garlic Naan)</p> <p>Asian food (Rainbow Roll Sushi, Edamame, Hot & Sour Soup)</p> <p>Mark IS NOT a vegetarian.</p>
<p>1 Quart Acetone This is used to clean some of his props and not for pyro.</p> 	<hr/> <p>Drinks:</p> <p>3 Room Temperature Bottled Water Cold Cranberry Juice</p> <hr/> <p>Timing:</p> <p>Drinks upon arrival. Food - Check with Mark (usually after the show)</p> <hr/>
<p>1 Quart or Gallon of Coleman Fuel If you are doing open flame and Mark is flying to your venue.</p>  <p>OPTIONAL</p>	<p>NOTE ON FOOD: This is just a guide. Mark is EXTREMELY FLEXIBLE and can adapt to any set up or food options. Mark likes every kind of food in the world. If there is a local dish or famous local restaurant please surprise him....except for brussels sprouts!!!</p>

Mark Nizer TECH GUIDE

Sound



Sound Check:

- Check levels of:
 - Mark's Wireless Mic: (DO NOT INCLUDE IN MONITORS)
 - Mark's Computer: (Play thru monitors.) See Figure below for *Audio Set Up Options*.
 - Mark's iPhone: for backup. (Play thru monitors.)
 - Stage Mic: for backup (or if needed for intro.)
- After sound check leave Mark's Wireless Mic and Computer levels up and live.
- Mark will mute and unmute his Wireless Mic as needed during the show.

Pre show:

- Pre-show and post-show music comes from the Computer audio out.
- Check that Mark's Wireless Mic and Computer are working, on and live.

Beginning of show:

- If there is an Stage Mic used to introduce Mark, turn it off after intro.
- Be prepared to adjust Mark's Computer audio levels for video introduction.
- Be prepared to adjust Mark's Wireless Mic levels when he first begins to speak. (approx. 1 minute and 48 seconds after he arrives on stage).

During Show:

- Keep Mark's Wireless Mic feedback free.
- Keep Mark's Computer levels loud and in monitors.

If Mark has technical problems with his Mic or Computer (or if they are distorted) TELL MARK ASAP. He may use your Stage Mic (to replace his headset) or his iPhone (to replace a failed computer). Mark has an extra mic headset with him on stage. If there is an issue with something not sounding right or dropping out, YOU MUST COMMUNICATE THIS TO MARK, as he often can't hear if there is a problem from stage.

End of Show:

- LEAVE COMPUTER AND MARK'S WIRELESS MIC UP AND LIVE
- You can turn off the sound board 10 minutes after the SHOW CREDITS END.

Audio Set Up Details.

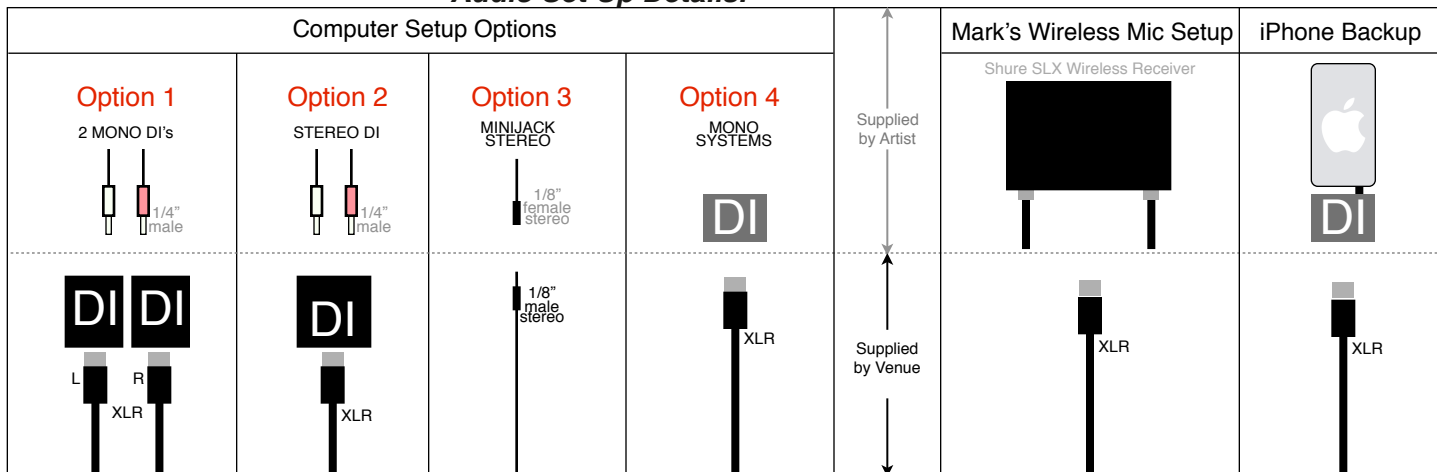

For more info visit [Nizer.com](http://www.nizer.com)

A downloadable version of this can be found at: <http://www.nizer.com/pages/resources.html>

Mark Nizer • 434 974 9699 • mark@nizer.com

Mark Nizer TECH GUIDE

Light Plot



NOTE: If you have DMX available Mark will run all light cues via his computer. If DMX is not an option or there are too many moving lights to easily take control via DMX, Mark can also run cues via Midi Show Control (MSC). Most modern lighting boards support this feature. In some cases Mark will bring lights with him and this plot is not needed.

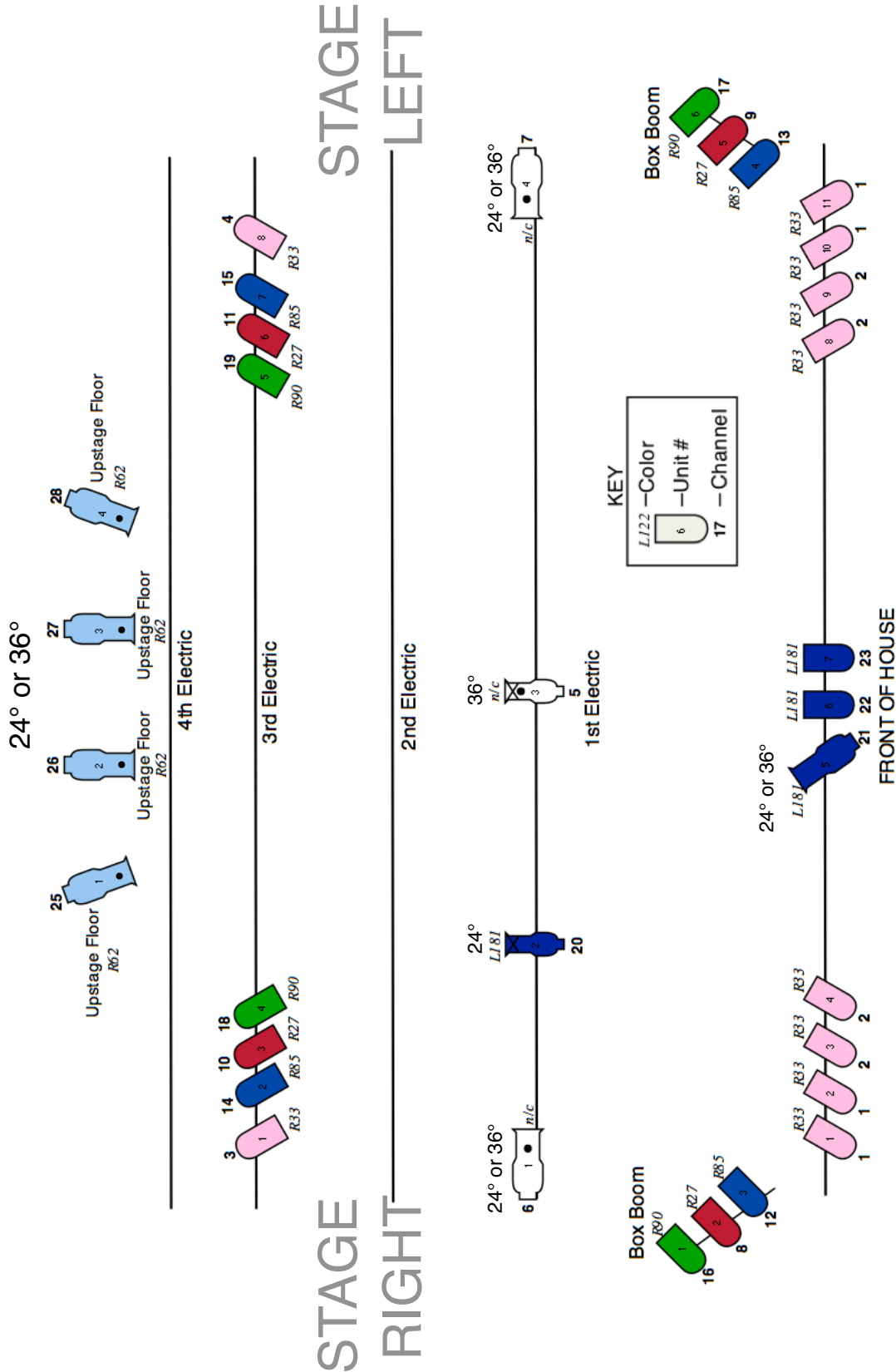

NOTE: Please try to keep FRONT LIGHT off the CYC or movie screen.

NOTE: Larger Venues may wish to double this plot and add extra instruments



If you are doing the 4D version of the show make sure you have ordered your glasses at least 2 weeks in advance at <http://nizer.com/3d>



For more info visit [Nizer.com](http://www.nizer.com)

A downloadable version of this can be found at: <http://www.nizer.com/pages/resources.html>

Mark Nizer • 434 974 9699 • mark@nizer.com



READ THIS TOO !

The sheets that follow are to help lighting designers and stage managers with detailed instructions. For many venues NONE of this applies. It is here for those that can use it.

Additional cue info is included here for special situations where a back up system may be required. This is extremely rare but always better to be prepared.



Typically, I patch the lights using a custom iPhone app I built. I will work with your light person to decide the best way to complete this process.

For more info visit **Nizer.com**

A downloadable version of this can be found at: <http://www.nizer.com/pages/resources.html>

Mark Nizer • 434 974 9699 • mark@nizer.com



TECH GUIDE

Lights Channel Info



C#	Dim #	Label	Position	Unit Type	Focus Position	Color
1		White	FOH #'s 1-2-10-11	4 Pars or Fresnels Appropriate size to wash the stage	Full Wash	White or no color pink (R33)
2		White	FOH #'s 3-4-8-9	4 Pars or Fresnels Appropriate size to wash the stage	Full Wash	White or no color pink (R33)
3		White	3rd elec #1	Par or Fresnel Appropriate size to wash the stage	Full Wash	White or no color pink (R33)
4		White	3rd elec #8	Par or Fresnel Appropriate size to wash the stage	Full Wash	White or no color pink (R33)
5		FANS	1st elec #3	Leco or ERS	Straight down	White with Gobo break up. Crisp focus 5-10' wide circle
6		8 Boxes	1st elec #1	Leco or ERS	Stage left	White with Gobo break up. To cover stage
7		8 Boxes	1st elec #4	Leco or ERS	Stage Right	White with Gobo break up. To cover stage
8		RED	L BoxBoom	Par or Fresnel Appropriate size to wash the stage	center stage	MEDIUM RED Roscol R27, Lee 27, Apollo AP8350, GAM 250
9		RED	R BoxBoom	Par or Fresnel Appropriate size to wash the stage	center stage	MEDIUM RED Roscol R27, Lee 27, Apollo AP8350, GAM 250
10		RED	3rd elec #3	Par or Fresnel Appropriate size to wash the stage	center stage	MEDIUM RED Roscol R27, Lee 27, Apollo AP8350, GAM 250
11		RED	3rd elec #6	Par or Fresnel Appropriate size to wash the stage	center stage	MEDIUM RED Roscol R27, Lee 27, Apollo AP8350, GAM 250
12		BLUE	L BoxBoom	Par or Fresnel Appropriate size to wash the stage	center stage	DEEP BLUE Rosco #R85, Lee 85, Apollo AP4050, Gam 890
13		BLUE	R BoxBoom	Par or Fresnel Appropriate size to wash the stage	center stage	DEEP BLUE Rosco #R85, Lee 85, Apollo AP4050, Gam 890
14		BLUE	3rd elec #2	Par or Fresnel Appropriate size to wash the stage	center stage	DEEP BLUE Rosco #R85, Lee 85, Apollo AP4050, Gam 890
15		BLUE	3rd elec #7	Par or Fresnel Appropriate size to wash the stage	center stage	DEEP BLUE Rosco #R85, Lee 85, Apollo AP4050, Gam 890
16		GREEN	L BoxBoom	Par or Fresnel Appropriate size to wash the stage	center stage	DARK YELLOW GREEN Rosco R90, Lee 90, Apollo AP5400, Gam 655
17		GREEN	R BoxBoom	Par or Fresnel Appropriate size to wash the stage	center stage	DARK YELLOW GREEN Rosco R90, Lee 90, Apollo AP5400, Gam 655
18		GREEN	3rd elec #4	Par or Fresnel Appropriate size to wash the stage	center stage	DARK YELLOW GREEN Rosco R90, Lee 90, Apollo AP5400, Gam 655
19		GREEN	3rd elec #5	Par or Fresnel Appropriate size to wash the stage	center stage	DARK YELLOW GREEN Rosco R90, Lee 90, Apollo AP5400, Gam 655
20		CONGO or UV	1st elec #2	Leco or ERS Dependent on Venue	Straight down	UV / CONGO BLUE Rosco R382, Lee 181, Apollo AP3850, Gam 930
21		CONGO or UV	FOH #5	Leco or ERS Dependent on Venue	Stage right	UV / CONGO BLUE Rosco R382, Lee 181, Apollo AP3850, Gam 930
22		CONGO or UV	FOH #6	Par or Fresnel Appropriate size to wash the stage	Center stage	UV / CONGO BLUE Rosco R382, Lee 181, Apollo AP3850, Gam 930
23		CONGO or UV	FOH #7	Par or Fresnel Appropriate size to wash the stage	Center stage high	UV / CONGO BLUE Rosco R382, Lee 181, Apollo AP3850, Gam 930
24		House Lights	n/a	Built in	n/a	n/a
25		LIGHT BLUE	Upstage Floor	Leco or ERS	see plot	LIGHT BLUE with GOBO BREAKUP Rosco R62, Lee 61, Apollo AP4700, Gam 820
26		LIGHT BLUE	Upstage Floor	Leco or ERS	see plot	LIGHT BLUE with GOBO BREAKUP Rosco R62, Lee 61, Apollo AP4700, Gam 820
27		LIGHT BLUE	Upstage Floor	Leco or ERS	see plot	LIGHT BLUE with GOBO BREAKUP Rosco R62, Lee 61, Apollo AP4700, Gam 820
28		LIGHT BLUE	Upstage Floor	Leco or ERS	see plot	LIGHT BLUE with GOBO BREAKUP Rosco R62, Lee 61, Apollo AP4700, Gam 820



TECH GUIDE

Light Patch Numbers Form



Channel	Group	Color Gobo	Dimmer
1	White - FOH - Right	R33	
2	White - FOH - Left	R33	
3	White - Back Right	R33	
4	White - Back Left	R33	
5	Fans Gobo	Fan like Gobo	
6	Leco Right	Stripped Gobo	
7	Leco Left	Stripped Gobo	
8	Red - FOH - Right	R27	
9	Red - FOH - Left	R27	
10	Red - BACK - Right	R27	
11	Red - BACK - Left	R27	
12	Blue - FOH - Right	R85	
13	Blue - FOH - Left	R85	
14	Blue - BACK - Right	R85	
15	Blue - BACK - Left	R85	
16	Green - FOH - Right	R90	
17	Green - FOH - Left	R90	
18	Green - BACK - Right	R90	
19	Green - BACK - Left	R90	
20	Piano Overhead	R382 / UV	
21	Piano FOH	R382 / UV	
22	UV Center Low	R382 / UV	
23	UV Center High	R382 / UV	
24	House Lights		
25	Floor Lights Right	R62 + Gobo Breakup	
26	Floor Lights Left	R62 + Gobo Breakup	

For more info visit [Nizer.com](http://www.nizer.com)

A downloadable version of this can be found at: <http://www.nizer.com/pages/resources.html>

Mark Nizer • 434 974 9699 • mark@nizer.com

Light Focus - 8 Boxes



S
T
A
G
E

S
T
A
G
E

L
E
F
T

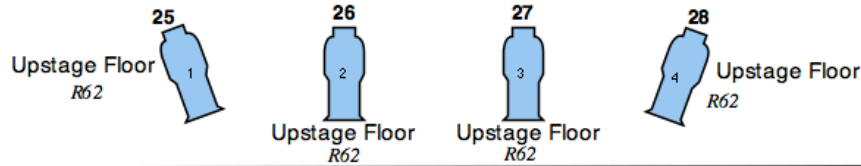

4th Electric

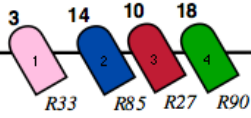

3rd Electric

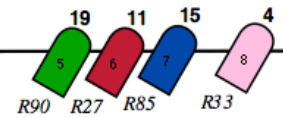

R
I
G
H
T

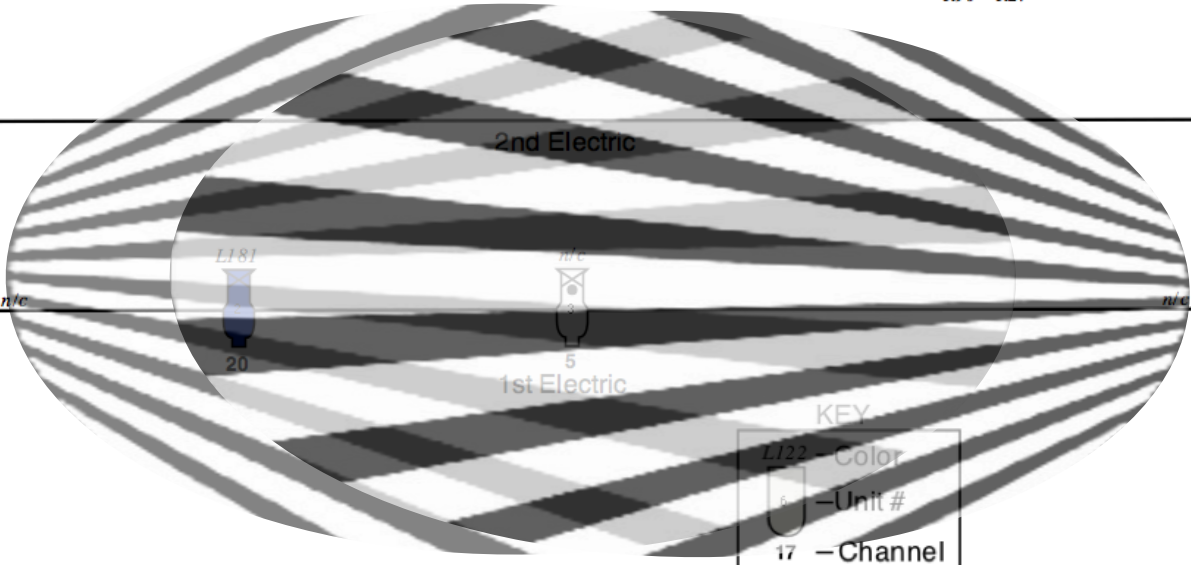

2nd Electric

1st Electric

KEY

- L122 - Color
- 8 - Unit #
- 17 - Channel

Box Boom

Box Boom

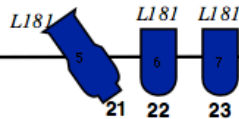
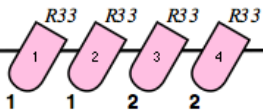
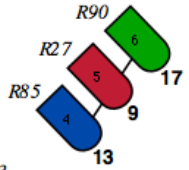
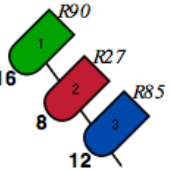

FRONT OF HOUSE

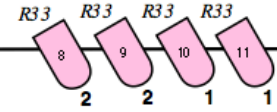

Position	Light	GOBO (example)	Notes
1&4	Leco	open white with Gobo breakup 	GOBO break up similar to Rosco Standard Steel Gobo #78047A Perspective Lines 2. This are just examples. We are VERY FLEXIBLE about these. If moving lights are available you can supplement this with a slow striped look slowly rotating.

Mark Nizer TECH GUIDE

Light Focus—UV/CONGO BLUE look 1



S
T
A
G
E

S
T
A
G
E

R
I
G
H
T

L
E
F
T

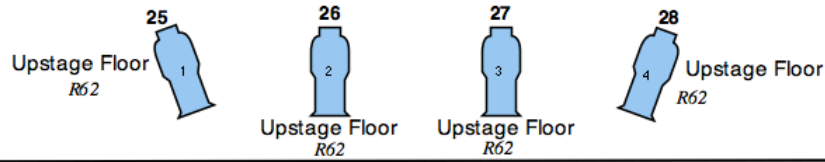

4th Electric

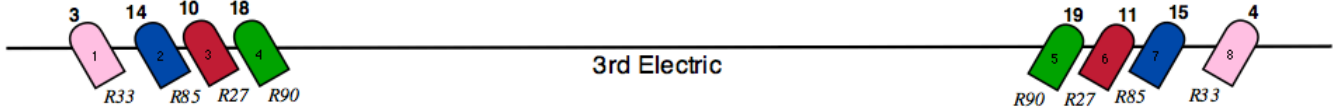

2nd Electric

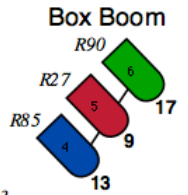
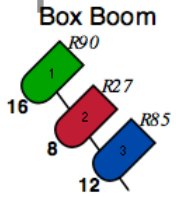
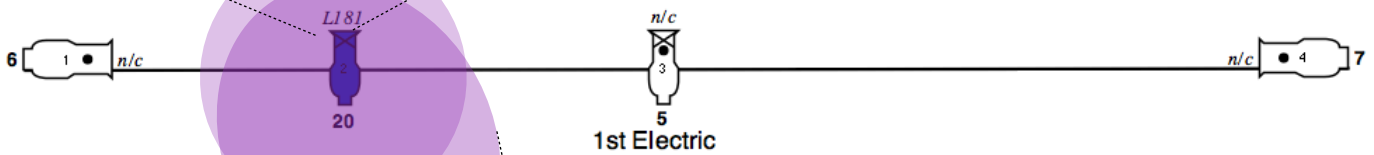

KEY

L122 —Color

6 —Unit #

17 —Channel

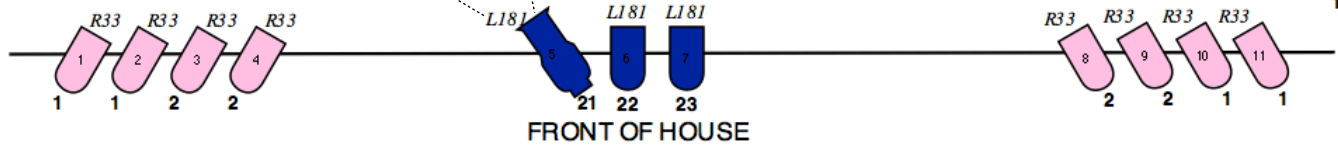

Position	Light	Gel	Notes
First Electric #20 FOH #21	Par or Fresnel Appropriate size to wash the area	UV or Lee Color 181 Congo Blue	If moving lights are available use those with UV lens.

Mark Nizer TECH GUIDE

Light Focus-UV/CONGO BLUE look 2

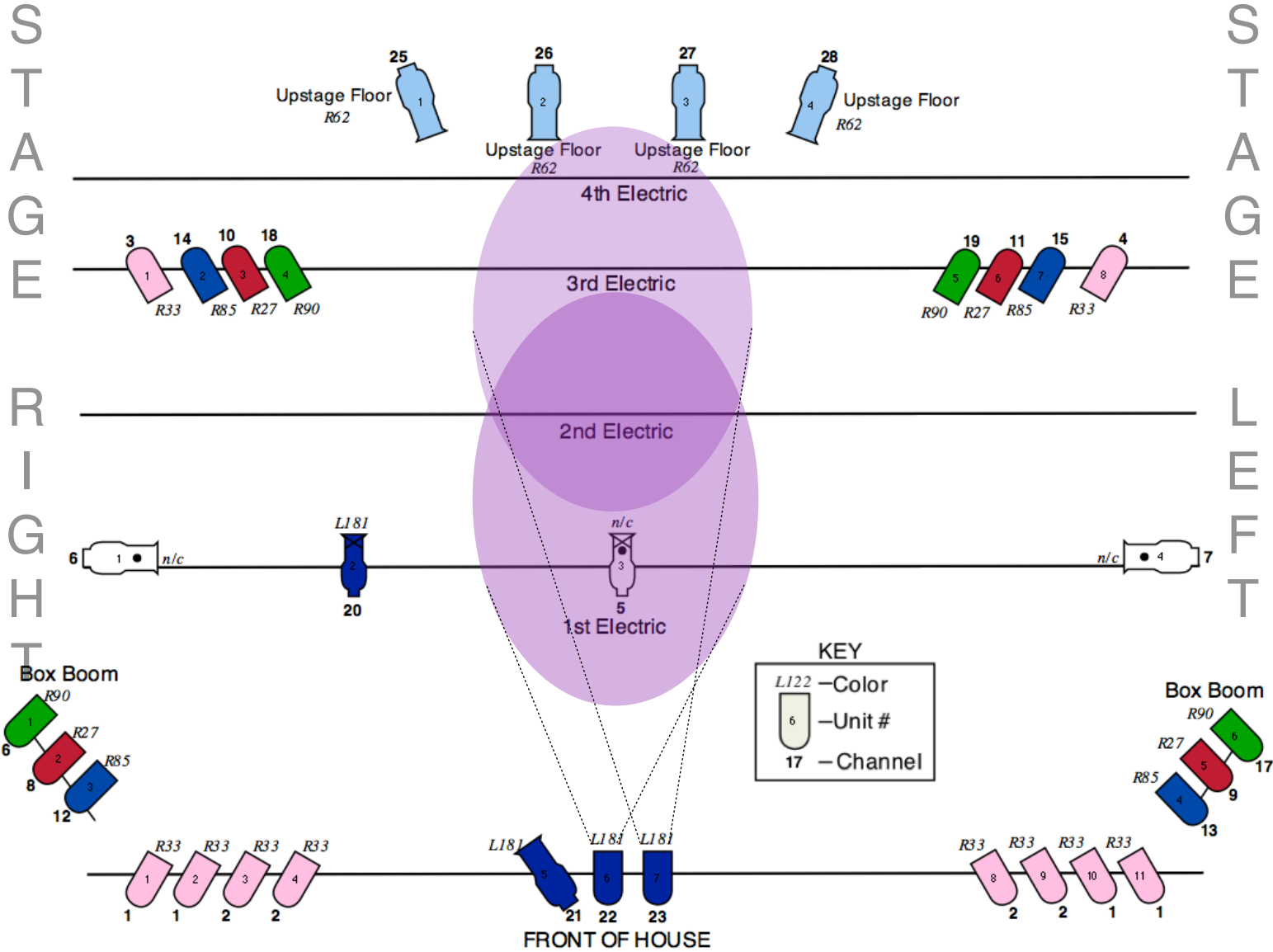

Position	Light	Gel	Notes
FOH 22&23	Par or Fresnel Appropriate size to wash the area	UV or Lee Color 181 Congo Blue	If moving lights are available use those with UV lens. Stack these two lights on top of each other to make a figure 8, covering the center of the stage to the ceiling.

For more info visit [Nizer.com](http://www.nizer.com)

A downloadable version of this can be found at: <http://www.nizer.com/pages/resources.html>

Mark Nizer • 434 974 9699 • mark@nizer.com



TECH GUIDE

Light Focus-White Look

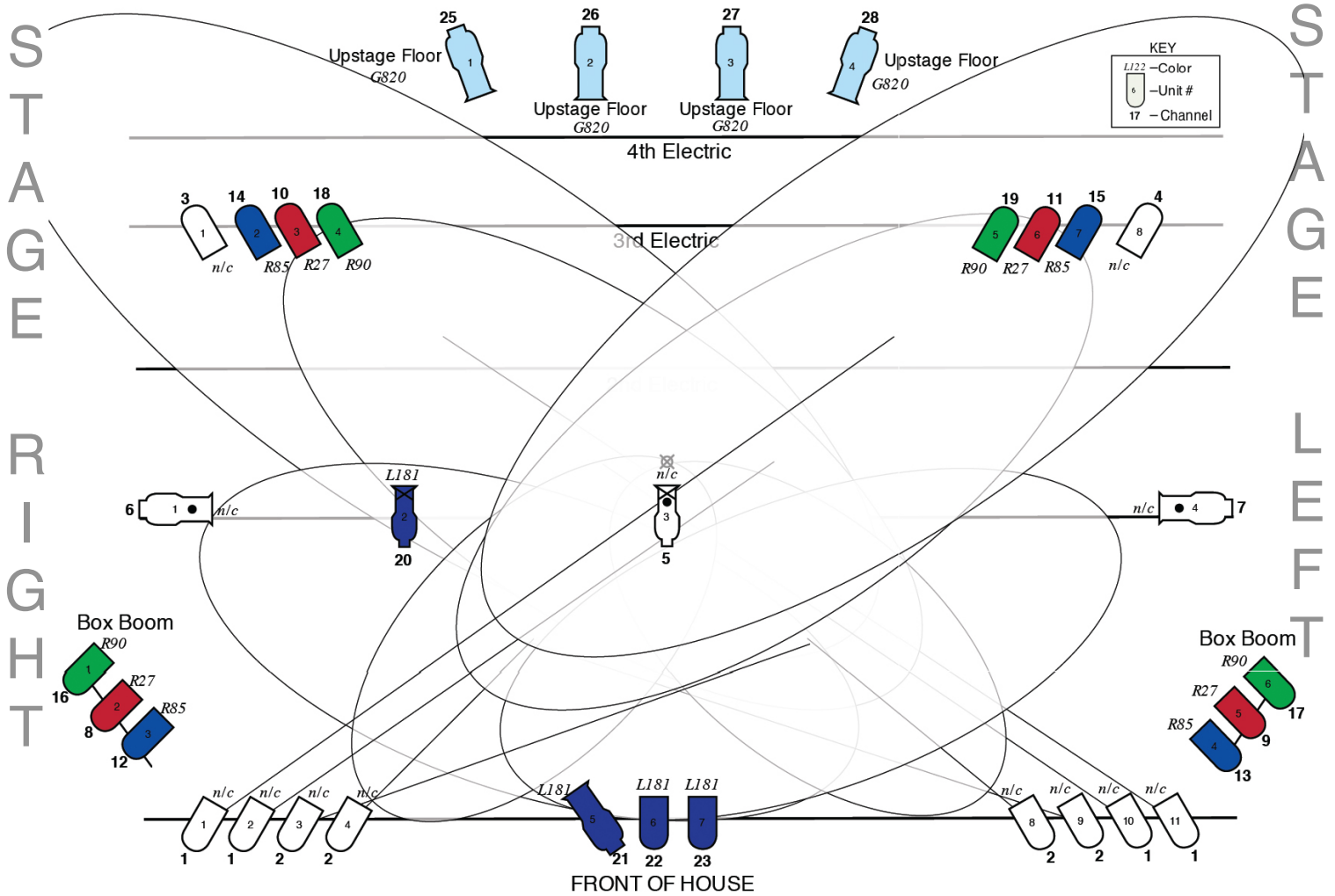

Position	Light	Gel	Notes
FOH 1-4 8-11	Par or Fresnel Appropriate size to wash the area	NC	If moving lights are available Mark may add these with a sharp gobo break up.

For more info visit [Nizer.com](http://www.nizer.com)

A downloadable version of this can be found at: <http://www.nizer.com/pages/resources.html>

Mark Nizer • 434 974 9699 • mark@nizer.com



TECH GUIDE

Light Focus - BLUE

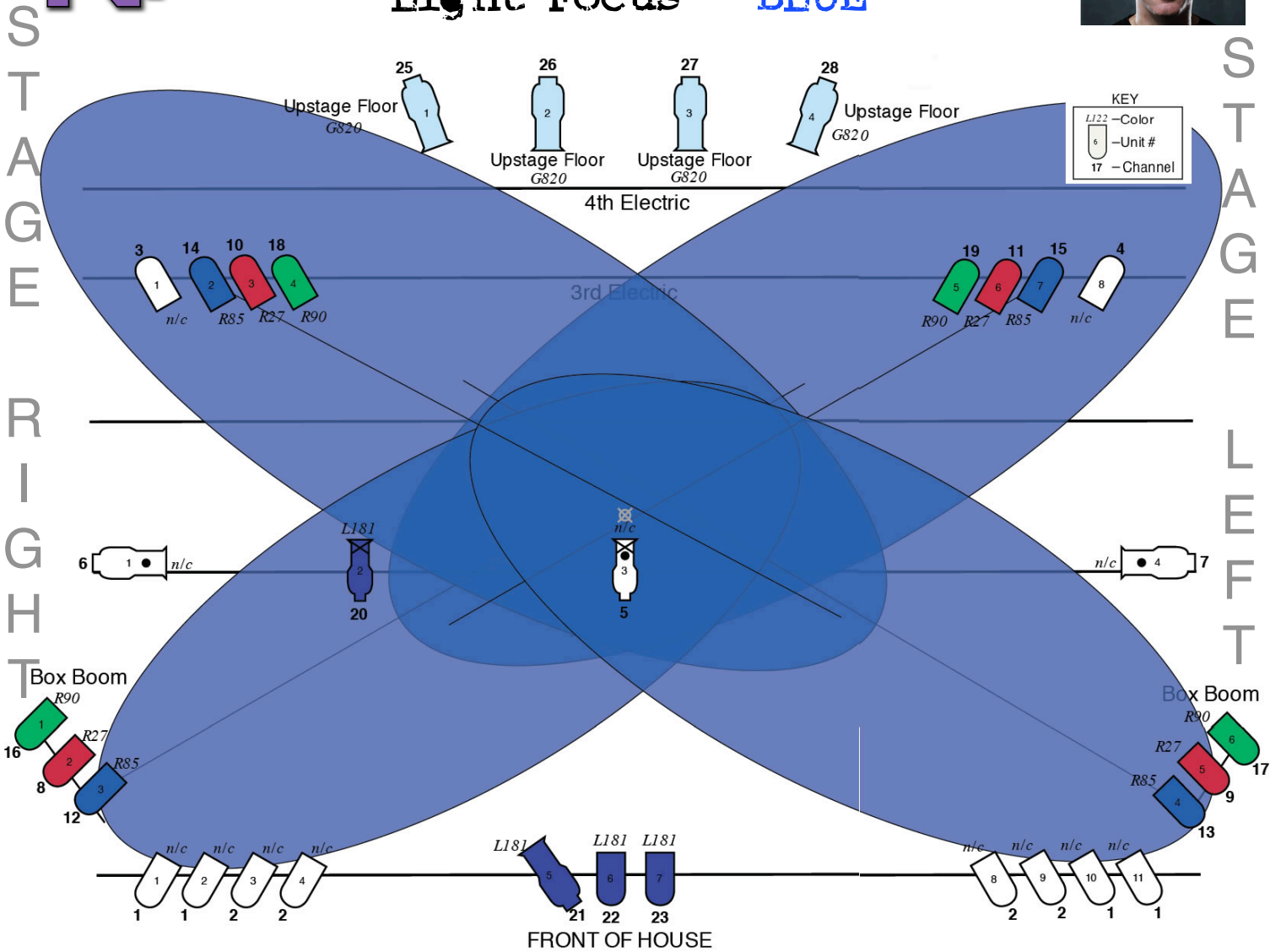

Position	Light	Gel	Notes
Box Booms 3&4	Par-MED Lens	Roscolux #R85 Medium Blue	If moving lights are available add those with a gobo and slow rotation or movement. THINK UNDER WATER!!!
3rd Electric 2&7			

For more info visit [Nizer.com](http://www.nizer.com)

A downloadable version of this can be found at: <http://www.nizer.com/pages/resources.html>

Mark Nizer • 434 974 9699 • mark@nizer.com



TECH GUIDE

Light Focus - GREEN



S
T
A
G
E

R
I
G
H
T

S
T
A
G
E

L
E
F
T

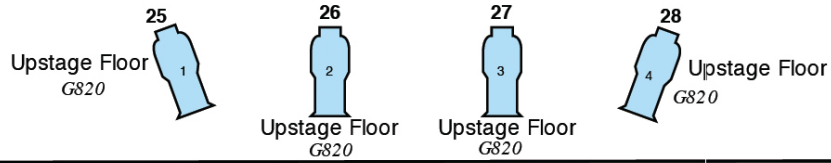

KEY	
L122	-Color
6	-Unit #
17	-Channel

4th Electric

3rd Electric

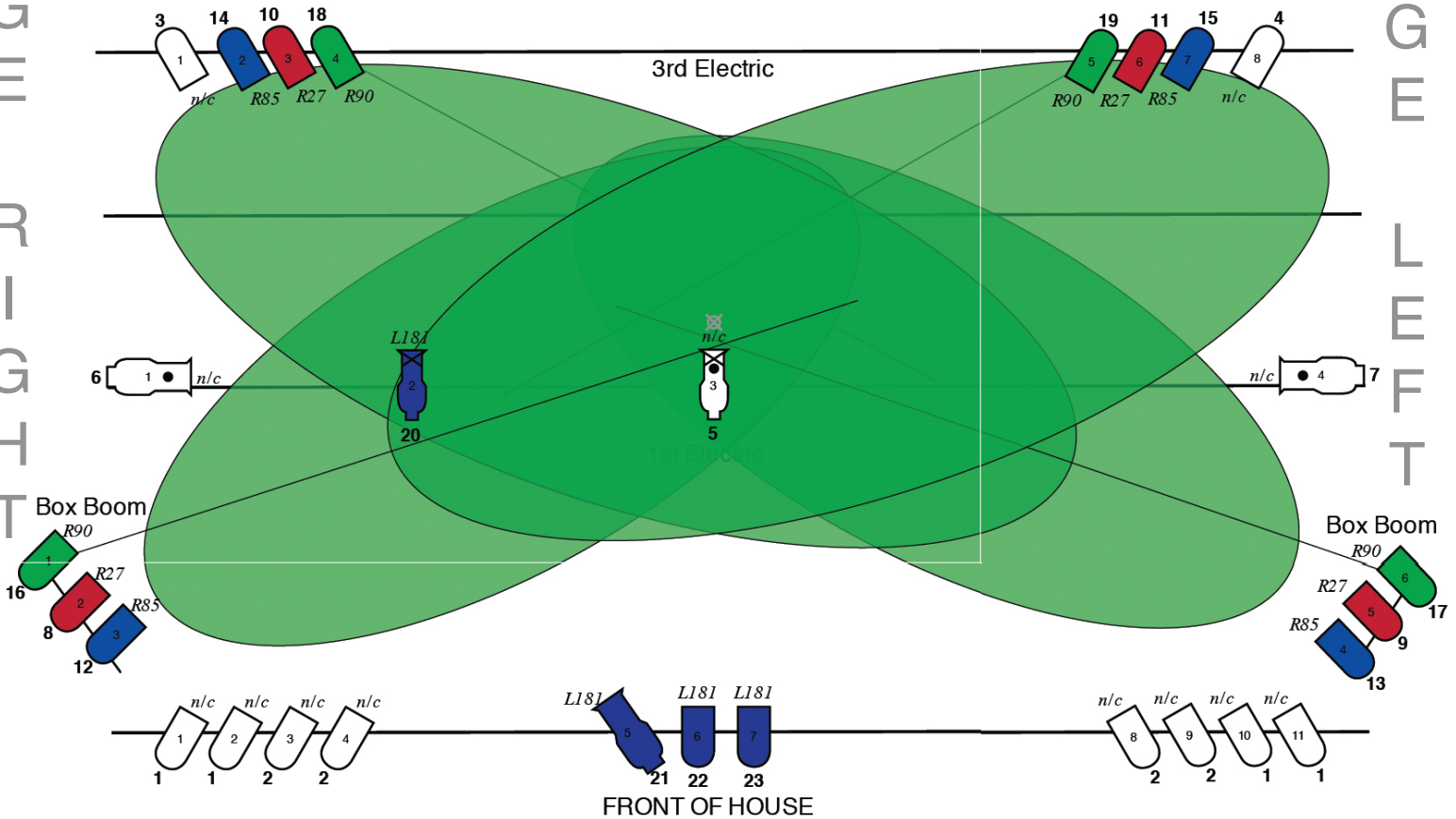

Position	Light	Gel	Notes
Box Boom 1&6	Par-MED Lens	YELLOW GREEN Similar to Roscolux #R90	Wash spread out in the area indicated. Blended together.
3rd Elec. 4&5			If moving lights are available create a neon green look with rings.

For more info visit [Nizer.com](http://www.nizer.com)

A downloadable version of this can be found at: <http://www.nizer.com/pages/resources.html>

Mark Nizer • 434 974 9699 • mark@nizer.com



TECH GUIDE

Light Focus - RED

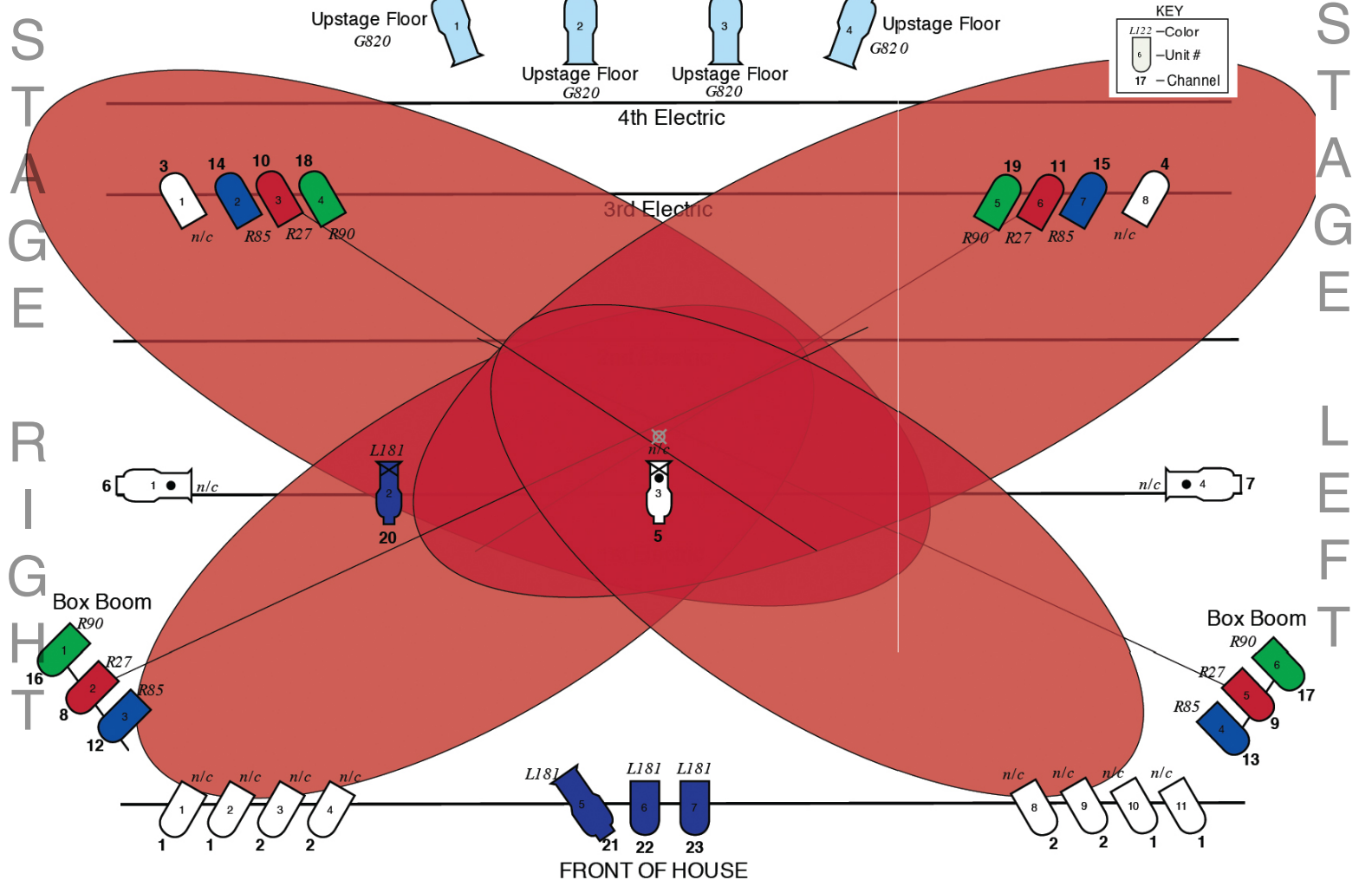

Position	Light	Gel	Notes
Box Boom 2&5 3rd Elec. 3&6	Par-MED Lens	Red = BLOOD RED similar to Roscolux #27: Medium Red	OPTIONAL RED GOBO break up wash spread out in the area indicated. Blended together. If intelligent lights are available add those with slow rotation or movement. Think FIRE!

For more info visit [Nizer.com](http://www.nizer.com)

A downloadable version of this can be found at: <http://www.nizer.com/pages/resources.html>

Mark Nizer • 434 974 9699 • mark@nizer.com



TECH GUIDE

Light Focus - FANS

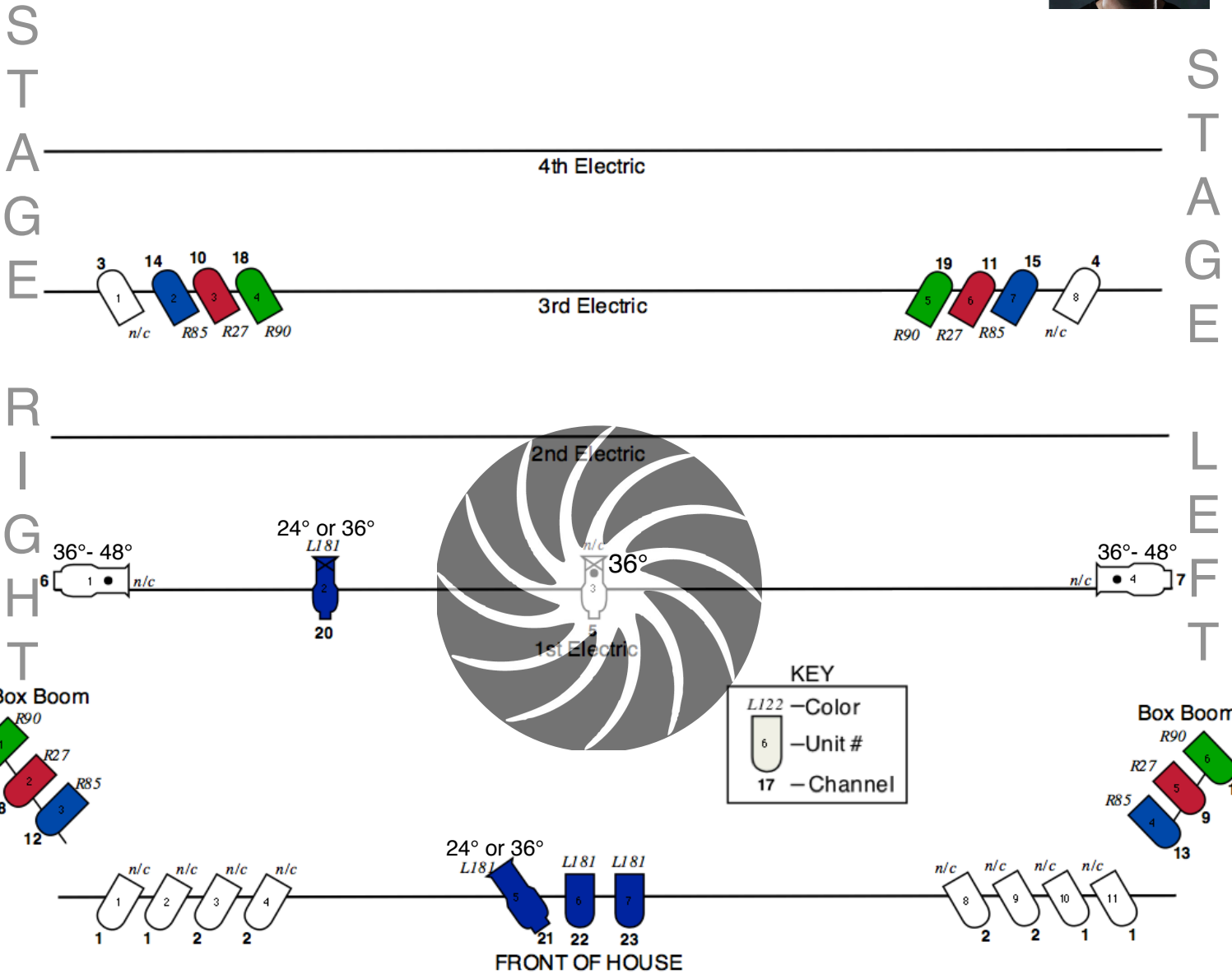

Position	Light	GOBO (example)	Notes
1st Electric #3	Leco 19°	White with Gobo "FAN LIKE" break up. Crisp focus 5-10' wide circle 	Please position the light unit straight down. We are VERY FLEXIBLE about these. OPTIONAL: If intelligent lights are available; ADD those and have 2 circle fan gobos; at first stationary, then when the fans are turned on they begin to rotate.

For more info visit [Nizer.com](http://www.nizer.com)

A downloadable version of this can be found at: <http://www.nizer.com/pages/resources.html>

Mark Nizer • 434 974 9699 • mark@nizer.com





S
T
A
G
E

S
T
A
G
E

R
I
G
H
T

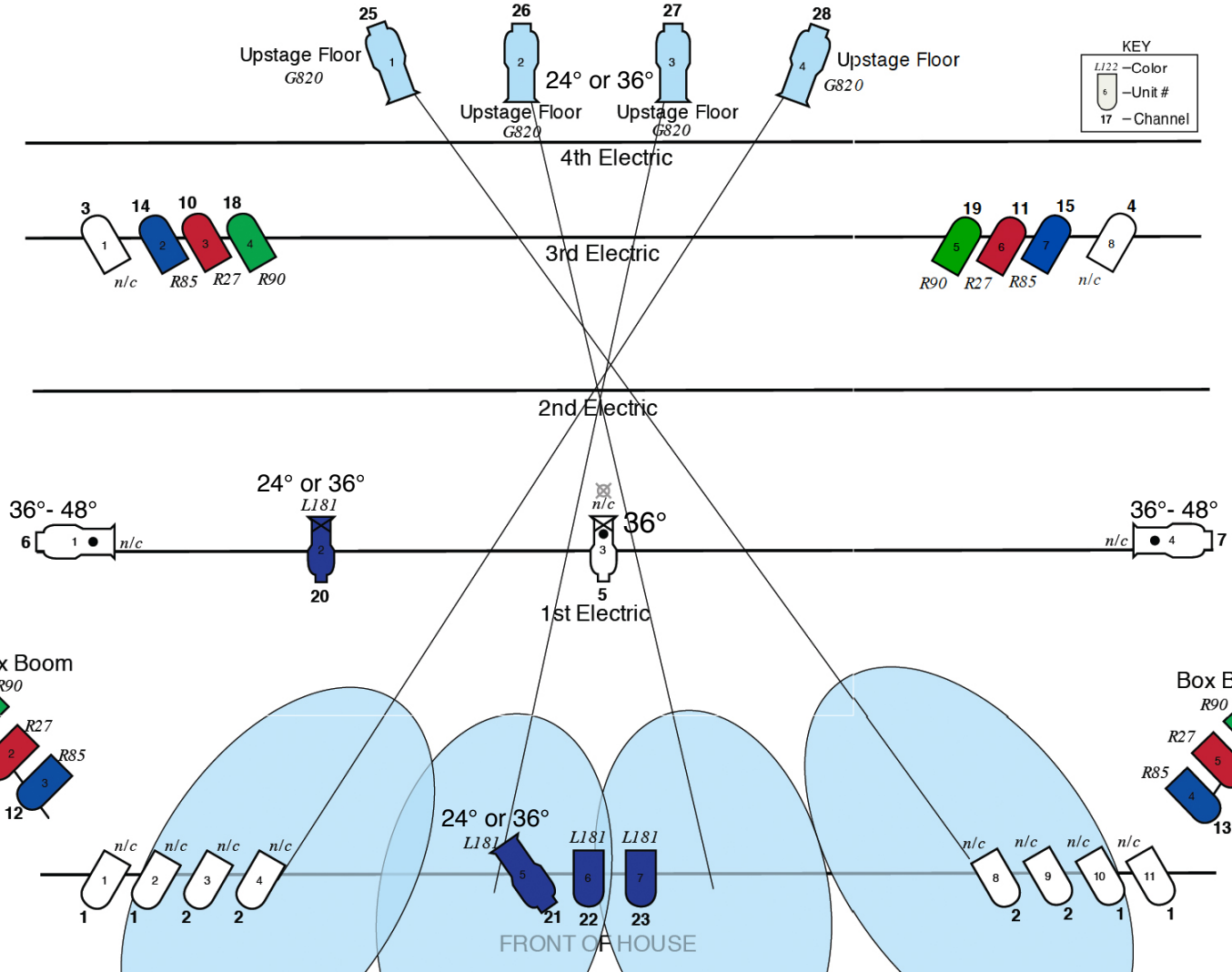
L
E
F
T



Position	Light	GOBO (example)	Notes
Upstage Floor	Leco 19° change as needed	White with Gobo break up. Crisp focus above audiences heads 	Splash on curtain and back stage is OK as one of the purposes of these units is to give Mark back light to see.



TECH GUIDE

Emergency Light Cues Part 1



Mark runs all light cues from his computer (via DMX or MSC).
If there is a problem this backup system is for that rare occurrence.

CH	MSC	AVOLITE	DESCRIPTION	ACTION
Red	1	1	PRESHOW	RED at 25% with HOUSE at 50%
Full	2	2	INTRODUCTION	A Partial Wash or SPECIAL
B/O	3	ALL OFF	After Mark is introduced - Video intro begins	BLACK OUT
Full	4	2	When " Building Colapses " in Video (Back light ON)	HOUSE UP to 60% and FULL WASH
Full	5	2	When Mark gets to stage	HOUSE OFF and FULL WASH
Full	5	2	3 BALLS	FULL WASH
RGB	20-22	6,7,8	METAL PIPE (Devil Stick)	RED-BLUE-GREEN each time Mark hits pipe with sticks
Full	5	2	3 CIGAR BOXES	FULL WASH
B/O	3	ALL OFF	When Mark looks up from book at prop table.	BLACKOUT for 2 seconds
Full	5	2	Restore Full wash	FULL WASH
Full	6	3	8 CIGAR BOXES	1 or 2 SPOTLIGHTS or SPECIAL
Full	5	2	When Mark catches the wine glass	FULL WASH
Full	5	2	UNICYCLE AND 2 VOLUNTEERS	FULL WASH
UV	7	4	BALL BOUNCING/PIANO	BLACK LIGHTS or CONGO BLUE WASH
Full	5	2	When Routine Ends	FULL WASH
Full	5	2	BALL SPINNING	FULL WASH
B/O	3	ALL OFF	UNDERWATER VIDEO When Mark says "Going for a quick swim"	BLACKOUT NOTE!!! Make certain ALL lights including backstage rail lights are OFF!
B/O	3	ALL OFF	ROBOTS 1 - Windows Vista	Stay in BLACKOUT
UV	8	5	ROBOTS 2 - Windows 7 When Mark removes the glow suit	ADD Black Lights or Congo Blue
BLUE	9	6	3 CLUBS - When you see the clubs	DARK BLUE
Full	5	2	When Mark turns on his BACK LIGHT	FULL WASH

NOTES: We will set a full wash that will be used most of the show.
A good rule is: if **Mark is juggling GO TO FULL!** If you see **Marks back light on GO TO FULL!**

For more info visit [Nizer.com](http://www.nizer.com)

A downloadable version of this can be found at: <http://www.nizer.com/pages/resources.html>

Mark Nizer • 434 974 9699 • mark@nizer.com



TECH GUIDE

Emergency Light Cues Part 2

Mark runs all light cues from his computer (via DMX or MSC).
If there is a problem this backup system is for that rare occurrence.



CH	MSC	AVOLITE	DESCRIPTION	ACTION
Green	10	6	LASER DIABOLO (Green glowing white prop)	GREEN
B/O	3	ALL OFF	When Mark says "KILL THE LIGHTS"	BLACKOUT Make certain ALL lights including backstage rail lights are OFF! TURN OFF or SHUTTER VIDEO PROJECTOR
Green	10	6	When Mark finishes with 2 Diabolos (end of 2nd piece of music).	GREEN TURN ON or UN-SHUTTER VIDEO PROJECTOR
Full	5	2	When Mark puts Diabolos away...	FULL WASH
RED	11	7	TORCHES: When Torches are lit on fire	DARK RED
Full	5	2	When Mark starts to juggle torches.	FULL WASH
Full	5	2	HEAD BOUNCE AND RINGS	FULL WASH
Full	12	9	PING-PONG BALLS	WHITE WASH
RED	11	7	BOWLING BALL -PRE LOOK	DARK RED
Full	5	2	Mark says "911", BOWLING BALL, TANK, KNIFE	FULL WASH
Full	13	10	When tricks ends.	BOW LOOK - HOUSE UP to 40%
Full	1	1	When Mark says "I'll do one more thing"	HOUSE OFF
I M P R O V	14	11	FANS in Place After Fans are set at center stage	OVERHEAD SPECIAL ONLY
	15	13	FANS - Fans are TURNED ON	OVERHEAD SPECIAL ROTATES + ACLs ON
	16	14	FANS Toilet Paper is Placed on FANS	WHITE SIDE TO SIDE FLASH .36 sec follow
	17	12	FANS-Impro (Good for in between)	OVERHEAD SPECIAL ROTATES ONLY
	18	13	FANS-Impro (Good for dramatic parts)	PLAY WITH MUSIC "2001" (Crazy Chase)
	19	15	FANS-Impro (Good for loud accents)	PLAY WITH MUSIC "2001" (Crazy Chase + ACLs)
Full	13	10	When Mark removes his LIGHT BELT	BOW LOOK - HOUSE UP to 40%
B/O	1	1	SHOW CREDITS When Mark leaves the stage after FAN BOWS	Stage lights OFF

NOTES: We will set a full wash that will be used most of the show. A good rule is: **if Mark is juggling GO TO FULL!**
If you see Marks back light "ON" GO TO FULL!

For more info visit [Nizer.com](http://www.nizer.com)

A downloadable version of this can be found at: <http://www.nizer.com/pages/resources.html>

Mark Nizer • 434 974 9699 • mark@nizer.com

Mark Nizer TECH GUIDE

Emergency Deck Cues



Mark has automated his show so this is for special situations only!

☑	Action	When?
	Screen OUT ↑	Mark arrives on stage.
	Take & Turn OFF Laser Tubes	Mark will bring them toward you stage right. Using a Paper Clip (provided) poke in the hole on the side of Laser Tubes and use a toggle motion to switch them off. Put clip and lasers somewhere safe. They are fragile.
	Strike Unicycle	Mark jumps off and brings unicycle toward stage right. Note: If Mark drops something while on the unicycle come out pick it up and hand it back to him.
	Throw Fake Arm	Mark juggles 3 machetes and throws 1 off stage right and you hear a scream.
	Screen IN ↓	Mark introduces the Piano piece.
	Screen OUT ↑	Mark finishes Piano piece. "We're Saved!!!"
	Screen IN ↓	Mark says "Going for a Quick Swim"
	1. Take & Turn OFF Robot Suit 2. Turn OFF Glow Balls	During Robot routine; come to stage Left. Mark will roll 3 glow balls off stage left and remove his robot suit. 1st: Come and take suit from Mark and turn it off. 2nd: Turn OFF balls by rotating the switches counter clockwise.
	Screen OUT ↑	After Robots ends. (after Mark juggles rings)
	COVER PROJECTOR	During the Laser Diabolo routine, when lights go to Blackout and Mark says "KILL THE PROJECTOR." ***Don't forget to uncover projector when the routine is finished!
	Place Fans	Mark puts his Bowling Ball back into his prop table. (or on Marks verbal cue) MAKE SURE FANS ARE LEVEL
	1. Screen IN ↓ 2. Remove Toilet Paper - IF REQUESTED -	Mark Leaves Stage: Clear toilet paper from blocking projector image.

SHOW TIME LINE
INTRODUCTION
3 BALLS
3 CIGAR BOXES
8 CIGAR BOXES
LASER TUBES
UNICYCLE AND 2 VOLUNTEERS
BALL BOUNCING
BALL SPINNING
UNDERWATER JUGGLING VIDEO
ROBOTS
CLUBS
LASER DIABOLO
TORCHES
HEAD BOUNCE RINGS
PING-PONG BALLS
BOWLING BALL, TANK, KNIFE
FANS



TECH GUIDE

Light Board MSC Setup



READ THIS: For venues with moving lights and/or a large built in plot (like ships), Mark will trigger all light cues wirelessly with his computer & iPad using Midi Show Control (MSC). If that is the case, this is a list of the cues we will build before the show. All cues must have **TRACKING OFF** and a **FADE TIME** of "0". Mark will trigger all cues during the show. Put these cues in their own cue list with the exact Cue numbers listed.

Cue #	CUE	LOOK	LOCATION
1	PRESHOW	Purple and Red sharp focused gobos all over the stage with HOUSE at 50%	<i>Downstage - Keep off Screen</i>
1.1	MSC Test Cue	COPY of cue 1 with a light added backstage right	<i>Downstage & Backstage</i>
2	INTRODUCTION	COPY of Cue 1 with WHITE FRONT added	<i>Center</i>
3	BLACKOUT	BLACK OUT	<i>n/a</i>
4	FULL WASH + HOUSE UP	FULL WASH with HOUSE ON at 75%	<i>Mostly center</i>
5	FULL WASH + HOUSE OFF	Copy of cue 4 with HOUSE OFF	<i>Mostly center</i>
6	8 CIGAR BOXES	White Strips with some light on prop table.	<i>Center</i>
7	BALL BOUNCING (PIANO)	Black Lights or Congo Blue Wash Stage Right	<i>Downstage Right</i>
8	ROBOTS PART 2	Black Lights or Congo Blue Full Stage	<i>Center, Stacked</i>
9	3 CLUBS	DARK BLUE - Think Underwater	<i>Center</i>
10	LASER DIABOLO	GREEN - Think Neon Green with red accents	<i>Center</i>
11	RED LOOK	DARK RED - Think Fire	<i>Center</i>
12	PING-PONG BALLS	WHITE WASH with White Dots	<i>Center</i>
13	BOW LOOK	BOW LOOK - HOUSE UP to 40%	<i>Everywhere</i>
14	FANS in Place	FANS SPECIAL - NO ROTATION	<i>Downstage Center</i>
15	Fans are TURNED ON	FANS SPECIAL with FAST ROTATION + ACLs	<i>Downstage Center</i>
16	FANS- Toilet Paper on	FANS SPECIAL with SIDE TO SIDE FLASH (.36sec) NOTE: This is also used on Double Ball spin.	<i>Downstage Center and Right and Left</i>
17	FANS - with rotation only	COPY of Cue 15 with ACL's OFF	<i>Downstage Center</i>
18	FANS ON and ACLS	COPY of Cue 15 with CRAZY CHASE ADDED	<i>Everywhere</i>
19	FANS-Improv 2	COPY of Cue 18 with ACL's ADDED NOTE: Include Cue 7 (Ball Bouncing) in this cue.	<i>Everywhere</i>
20	RED Quick	RED - Must be fast changing. If using movers use different fixtures for cue 20-22. LED fixtures are best for this.	<i>Center</i>
21	GREEN Quick	GREEN - Must be fast changing. If using movers use different fixtures for cue 20-22. LED fixtures are best for this.	<i>Center</i>
22	BLUE Quick	BLUE - Must be fast changing. If using movers use different fixtures for cue 20-22. LED fixtures are best for this.	<i>Center</i>

For more info visit [Nizer.com](http://www.nizer.com)

A downloadable version of this can be found at: <http://www.nizer.com/pages/resources.html>

Mark Nizer • 434 974 9699 • mark@nizer.com



TECH GUIDE

Avolite Pearl Light Board Setup



This is for venues that have mostly moving lights and use a Avolite Light Board ONLY!!!

FADER	Midi Note Trigger	DESCRIPTION	LOOK
1	0	PRESHOW	Colored Gobo Heavy patterns on floor
2	1	FULL	Full Wash
3	2	8 CIGAR BOXES	Black and White Strips
4	3	UV Piano	UV stage left down stage
5	4	UV Center	UV Center Stage
6	5	Blue	Blue Look - LED and Gobo Heavy
7	6	Green	Green Look - LED and Gobo Heavy
8	7	Red	Red Look - LED and Gobo Heavy
9	8	Ping Pong Balls	White dots and White lights
10	9	Bow Look	Lots of Moving and Color changes
11	10	Fans in Place	Two white fan gobos. Down stage, center with NO ROTATION
12	11	Fans with Rotation	Copy of Fader 11 with FAST ROTATION added
13	12	Fans with Rotation & ACLS	Copy of Fader 12 with ACLS added
14	13	Crazy Chase	Big Chase of lots of lights
15	14	Crazy Chase with ACLS	Copy of Fader 14 with ACLS added

Instructions:

Patch Qlab Midi Patch #8 to Nizer Show Net Interface. This set up lets you trigger any of the 16 faders using a midi ON note. A midi on note at 0 turns it off.

Each midi ON note of velocity higher then zero (127 being 100%) will turn on, one of the 16 faders. YOU MUST ALSO TURN OFF THE FADER with a 0 midi velocity. Velocity 0-127 is brightness 0-100%

To setup the lightboard go to the User Settings menu

This menu is obtained by holding down the AVO button and pressing C [User Settings]. You can also turn the key to System mode and press C [User Settings].

You select the option to change using the cursor up/down buttons, and make the changes using the left/right buttons.

Select Option:

14. Midi - SLAVE/MASTER/DISABLED/Visualiser - Sets the MIDI mode of the Pearl. YOU WANT SLAVE MODE!!!

15. Midi channel = xx - Sets the MIDI transmit / receive channel. MIDI channels are actually numbered 1-16, and the Pearl displays 0-15, so subtract 1 on the Pearl display to get the actual channel. Since I am using MIDI Channel 8 we will set the Avolite Midi channel to 7.

To Configure What Note Triggers what fader

-Utility menu

The Utility menu is accessed by turning the key to System, then pressing G [Utilities].

Select C from the soft keys [Configure a MIDI keyboard] - Lets you change which MIDI note turns on each memory. Send the MIDI note for memory 1, then the note for memory 2, and so on. A prompt is displayed on the VDU screen which tells you what the Pearl is expecting you to do. Press Exit to end.

To View Incoming Midi Data: *This is different on other Avolite boards. Check show Qlab file for more info.*

-Go to Service mode

-Service mode, selected by turning the key to "System" then pressing A [Service]

F [View MIDI codes] shows incoming MIDI commands on the VDU screen (press F again to close the window)

Plug in midi out of computer midi interface into midi in of light board.

MORE INFO HERE:

<http://www.avolites.com>

For more info visit [Nizer.com](http://www.nizer.com)

A downloadable version of this can be found at: <http://www.nizer.com/pages/resources.html>

Mark Nizer • 434 974 9699 • mark@nizer.com



TECH GUIDE

Introductions



NOTES:

This sheet is normally not used. If you wish to come out to welcome the audience and mention upcoming events, that would be fine.

Mark's computer will do a pre-show announcement that will include safety information, cell phone and photography rules and an introduction.

If you prefer not to go on stage and/or have sponsors you would like to thank or any other information that you would like to announce, Mark can add it to his show file before the show.

Minimal 1:

Mark Nizer has recently performed for the King of Thailand. He has performed for a sheik in Kuwait and even did a show for the sequestered OJ Simpson jury...Mark Nizer.

Minimal 2:

You may have seen him on Americas Most Wanted a record 3 times. He even performed for the sequestered OJ Simpson Jury. Ladies and GentlemenMark Nizer

Minimal 2:

Mark Nizer is the only performer in the world to have never appeared on America's Got Talent. He has been asked to be on 27 times from 6 countries and guaranteed to be in the finals in two of them. Ladies and GentlemenMark Nizer.

Longer 1:

Mark Nizer has appeared on Comic Strip Live and Caroline's Comedy Hour. Mark won 1st place in the International Juggling Championships and won the Comedy Entertainer of the Year. Performance Magazine called him "brilliant".....We call him the juggler your mother warned you about....Mark Nizer.

Longer 2:

Mark Nizer has appeared on Comic Strip Live and Caroline's Comedy Hour. Mark won 1st place in the International Juggling Championships...And won the Comedy Entertainer of the Year. He performed his one man show "My Brain is Full" at the Kennedy Center in Washington, DC. Performance Magazine called him "brilliant".....We call him the juggler your mother warned you about....Mark Nizer.

For more info visit [Nizer.com](http://www.nizer.com)

A downloadable version of this can be found at: <http://www.nizer.com/pages/resources.html>

Mark Nizer • 434 974 9699 • mark@nizer.com



TECH GUIDE

Load Out



If there is a stage crew, they can begin the load out process by following the instructions below. This is OPTIONAL and can be done while Mark is not present. Mark will join you ASAP.

CABLES:

1. Unplug and wrap up all XLR, Power and VGA cables. Mark's personal cables normally have red velcro straps and/or yellow and purple tape on them. Make sure to let any video projector run a cooling cycle before unplugging it. None of Mark's personal equipment can be damaged by unplugging it.
2. DO NOT TOUCH LAPTOP except for unplugging the VGA or HDMI. The mini display port to VGA/HDMI adapter belongs to Mark.

GOBOS and GELS:

1. Retrieve Gobo's and Gels that Mark supplied and put them on the computer table.

PIANO:

1. Carefully remove tape and roll up Piano floor and separate it from the computer interface by pulling straight out. Be very gentle with mini computer unit. Roll up the USB cable and put both on the computer table.

UNICYCLE: *only if Mark is flying out.*

1. REMOVE PEDDLES: They are detached where they connect to the silver crank shaft. Position the unicycle with the seat quick release to the back. The peddle to your right unscrews the normal direction. The left peddle unscrews the opposite direction. You should be able to unscrew it by hand. There is a thin black wrench (if needed) in the large green duffel bag side zipper pocket.
2. REMOVE SEAT SECTION: Release the tension on the quick release then twist the pipe out of the larger pipe. This is a tight fit and requires some strength. Close quick release.
3. PUT AWAY: Place the wrench (if used) and peddles back in the duffel bag side zipper section or black pouch inside the duffel bag and zip it closed. Put the cloth cover from the large section of the duffel around the seat to protect it. Place the seat section, then the wheel section in the duffel bag with the seat and wheel at opposites ends of the bag. Leave open.

DEFLATE BALLS: *only if Mark is flying out.*

1. Deflate 3 balls. 2 Volleyballs and the one medium yellow ball. Wet the needle tip well and gently insert approx. 1 inch into white or black valve. Apply pressure (sitting on it works well) being careful not to sit on the valve or ball needle. Have the needle point out, parallel to the ground.
2. Place them on the floor by my roller bag.

EMPTY CONTAINERS:

1. Empty water from red ping pong balls holder, being careful not to spill the ping pong balls. Put elastic band around red container once it is empty. Empty Wine Glass.
2. Empty the plastic bottle of fuel. If possible put it back in the original container it came in.

RETRIEVE Ping Pong Ball BOX and BALL DROP UNIT

1. In most venues there will be a paper box attached to a border or fly pipe.
2. Remove it and gently unfasten velcro connections to make box flat.
3. Undo velcro from ball drop unit and power it down via the small switch on the battery pack.

FOG MACHINE

1. Unplug from power supply. Unplug remote control from back of fogger. Wrap cords.
2. Unscrew cover and pour fog fluid out of fogger into plastic container (located in duffel).

For more info visit [Nizer.com](http://www.nizer.com)

A downloadable version of this can be found at: <http://www.nizer.com/pages/resources.html>

Mark Nizer • 434 974 9699 • mark@nizer.com



If you have actually gotten to this page you have done more than expected. Thank you for your attention to detail. I really appreciate your work and help preparing for my show. While I am not in danger of injury from not following the above guide and will not request only green M&M's in my dressing room; I love Snickers™ candy bars, one placed (only one, I don't want to get too fat) in my dressing room would confirm that you actually got here and are a hero to me.

For more info visit **Nizer.com**

A downloadable version of this can be found at: <http://www.nizer.com/pages/resources.html>

Mark Nizer • 434 974 9699 • mark@nizer.com